

Contents

ENGLISH	2
Vehicle Details	2
Adapter Kit Details	2
Compatible Compressors	3
Compressor Kit Configurations.....	3
Parts View List.....	4
Parts View	5
Foreword	6
Standard Fastener Torque Values	6
Pre-Installation	7
Installation	7
Compressor Bracket Installation.....	8
Compressor Modification.....	8
Compressor Installation	8
Drive Belt.....	9
Compressor Hoses	9
Post Installation.....	9
Notes.....	10
Notes.....	11
Notes.....	12

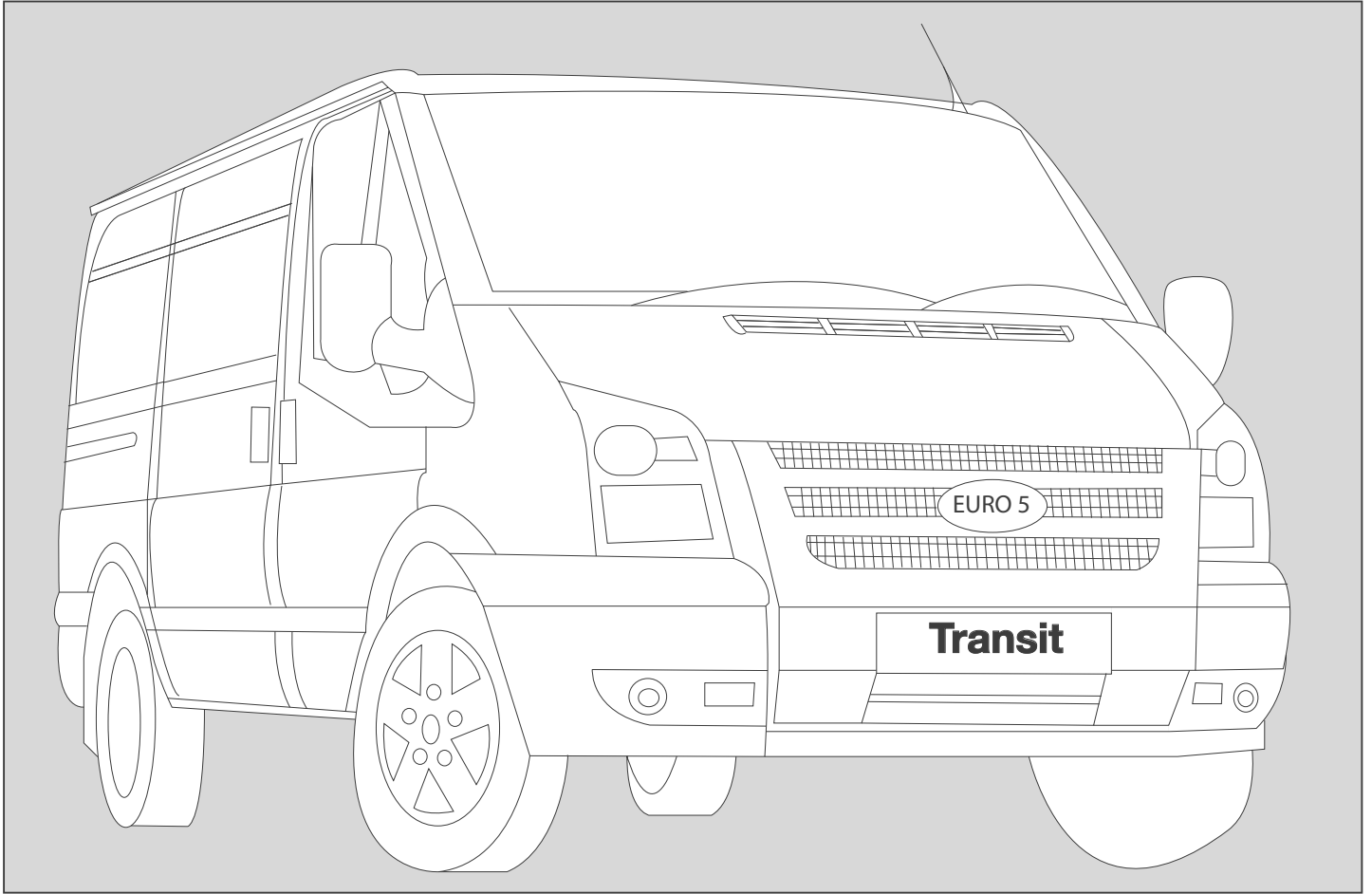

VEHICLE DETAILS

Manufacturer	Ford
Make	Transit FWD Euro 5
Model	250, 260, 280, 300, 330, 350
Engine CC	2198cc
Engine Details	100, 125, 140 PS
Year	11.2011 >
Chassis Nos.	N/A
LHD	YES
RHD	YES
PAS	YES
A/C	NO
Voltage	12v

ADAPTER KIT DETAILS

Kit Part No.	0500.6402
Description	Standard Kit
Compressor RPM	4705 @ Max engine power output
Fitting Time	90 Minutes
Suction Fitting	90°
Discharge Fitting	45°
Belt Type	6PK 1675
Belt Part No.	0820.0901

COMPATIBLE COMPRESSORS

SELTEC	TM-13 HS	TM15-HS	TM16-HS
Comp No	0381.0152	0381.0802	-
Seltec No.	488.44320	488.44320	-
Mounting	Ear	Ear	-
Rotor	8PV	8PV	-
Armature	SL	SL	-
Diameter	123	123	-
Voltage	12	12	-
Orientation	V	V	-
Fitting	3/4 x 7/8	3/4 x 7/8	-
Manifold	Bolt	Bolt	-

QUE	QP13-HD	QP15-HD	QP16-HD
Comp No	0391.0152	0391.0802	-
Que No.	-	QP15-1512	-
Mounting	Ear	Ear	-
Rotor	8PV	8PV	-
Armature	SL	SL	-
Diameter	123	123	-
Voltage	12	12	-
Orientation	V	V	-
Fitting	3/4 x 7/8	3/4 x 7/8	-
Manifold	Bolt	Bolt	-

SANDEN	SD5H09	SD5H14	SD5H15
Comp No	-	-	-
Sanden No.	-	-	-
Mounting	-	-	-
Rotor	-	-	-
Armature	-	-	-
Diameter	-	-	-
Voltage	-	-	-
Orientation	-	-	-
Fitting	-	-	-

Notes

COMPRESSOR KIT CONFIGURATIONS

PART NUMBER	COMPRESSOR KIT PART NOS				DESCRIPTION	QTY.
	0513.6402	0515.6402	0593.6402	0595.6402		
0381.0152	●				TM13 Ear Mount 8PV SL 123 12V V 3/4 x 7/8 Bolt	1
0381.0802		●			TM15 Ear Mount 8PV SL 123 12V V 3/4 x 7/8 Bolt	1
0391.0152			●		QP13 Ear Mount 8PV SL 123 12V V 3/4 x 7/8 Bolt	1
0391.0802				●	QP15 Ear Mount 8PV SL 123 12V V 3/4 x 7/8 Bolt	1

● = Additional parts to standard kits.

PARTS VIEW LIST

ITEM	PART NO.	DESCRIPTION	QTY.	COMMENTS
1	0441.2552	Compressor Mount Bracket Assembly	1	-
2	0440.2553	Compressor Mount Bracket	1	-
3	2800.0531	Split Dowel Bush	2	-
4	0290.3922	Fastener Pack - 0500.4062	1	Not Shown
5	2809.0011	Washer M10 Flat DIN 125 - A 10.5	1	-
6	2809.0101	M10 Schnorr safety washer type 'S'	1	-
7	2705.0301	Hex socket head cap screw M10 x 130 : 1.50 - 12.9	1	-
8	2735.0071	Durlok Hexagon Flange Nut - M10 : 1.50	1	-
9	2705.0491	Hex flange bolt durlok - M10 x 30 : 1.50 - 12.9	2	-
10	2704.1011	Hex flange bolt - M8 x 60 : 1.25 - 10.9	1	-
11	2704.1031	Hex flange bolt - M8 x 45 : 1.25 - 10.9	3	-
12	2704.1021	Hex flange bolt - M8 x 35 : 1.25 - 10.9	1	-
13	2734.0041	Hexagon Carp Nut - M8 :1.25	1	-
14	1705.0831	Automatic Belt Tensioner	1	-
15	1700.0491	Back Idle pulley 65 x 25.5	1	-
16	1700.0501	Idle pulley 68 x 26 - 6PK	1	Includes bolts
17	0820.0901	Belt - Poly Groove 6PK 1675	1	-
18	2705.5301	Hex flange bolt M10 x 35 : 1.50 - 8.8	1	-
19	3020.6141	Manifold clamp	1	
20	0426.5042	Fitting - Discharge	1	
21	0426.5032	Fitting - Suction	1	
22	1430.0142	Heat Shield Sleeve ID20, L0.5	1	
23	1430.0162	Heat Shield Sleeve ID30, L0.5	1	
24	2771.0471	P-Clip 45mm	1	
25	2704.1521	Hex flange bolt durlok - M8 x 16 : 1.25 - 12.9	1	
26	2803.5051	Threaded Pillar M8 x 20 Male Female	1	

Notes

PARTS VIEW

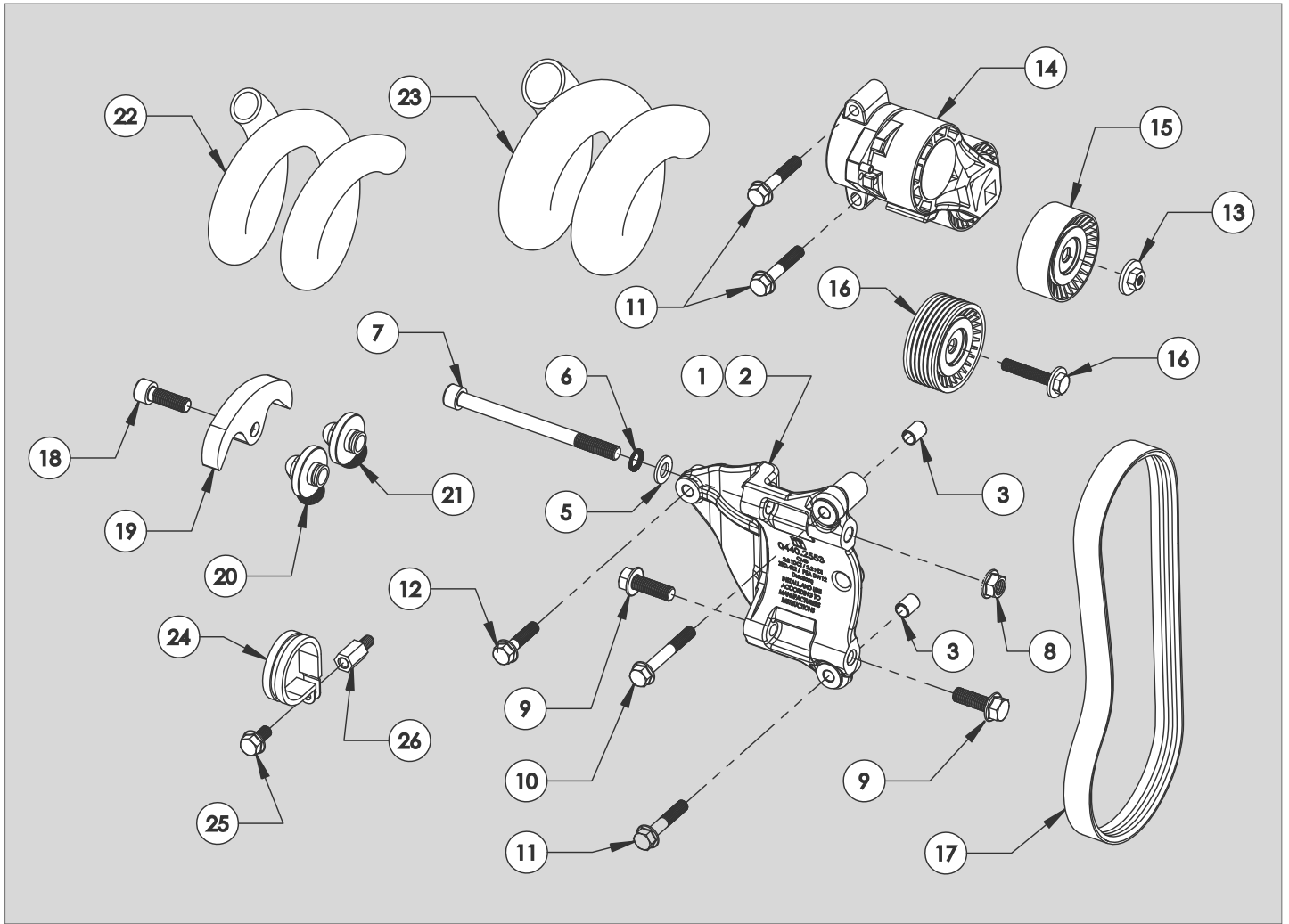

Notes

FOREWORD

- The purpose of this manual is to facilitate the installation of a direct drive compressor. The information given is merely instructive, should any complications arise contact the Technical department. The manufacturer's warranty does not cover any problems caused by defective installation or alterations made unless authorised. The manufacturer shall not be responsible for any injury, damage or loss caused directly or indirectly as a result of using this manual or the information contained within it.

1 SAFETY MEASURES:

Before fitting the Compressor adapter drive kit, ensure the following for damage:

- Inner and outer trim and body work
- Engine idle pace
- Check all the vehicle functions

Check list:

- Ensure that the right kit has been selected
- Before installing, check that all the correct pieces are present; also ensure that there are no missing or broken pieces
- When fitting, make sure the vehicle is properly protected against damage.

Installation apparatus

- Calibrated torque wrench
- Hand service tools
- Protective covers and shields

2 PRECAUTIONS

- Detach the battery negative lead.
- Torque all bolts where stated using a calibrated torque wrench.
- Take extreme care with moving parts.
- Remove the vehicles ignition key and keep it with you.
- Wear safeguards to make sure that liquid refrigerant never touches your skin





Caution: Measures must be followed accurately to steer clear of the possibility of damage to individuals

Warning: This calls awareness to actions which must be pursued to avoid damage to the components.

NB: This calls awareness to make the job easier or gives useful information.

STANDARD FASTENER TORQUE VALUES

- In the absence of specific torque values detailed in this fitting instruction manual, the following chart can be used as a guide to the maximum safe torque for specific size and grade of fastener.

STRENGTH								
	Max Torque		Max Torque		Max Torque		Max Torque	
Dia / Pitch	lb.ft	Nm	lb.ft	Nm	lb.ft	Nm	lb.ft	Nm
M5 x 0.80	2	3	4.5	6	6.5	9	7.5	10
M6 x 1.00	4	5.5	7.5	10	11	15	13	18
M8 x 1.25	10	13	18	25	26	35	33	45
M10 x 1.25	20	27	39	53	57	78	66	90
M10 x 1.50	18	25	37	50	55	73	63	86
M12 x 1.75	33	45	63	85	97	130	111	150
M14 x 2.00	55	75	103	140	151	205	177	240
M16 x 2.00	85	115	159	215	232	315	273	370

PRE INSTALLATION

NB Prior to commencing work, please examine the instructions with care. The alphabetical symbols on the diagram relate to written instructions, numerical symbols relate to the parts listing.

Dismantle the following:

1. Remove the original power steering stretch self tensioning drive belt (A) using the correct removal tool (Not supplied) - Fig 1
2. Remove and discard the original alternator stretch self tensioning drive belt (B) using the correct tool (Not supplied) - Fig 1.
3. Remove the 3 x M8 bolts securing the exhaust mounting bracket (C) shown - Fig 2

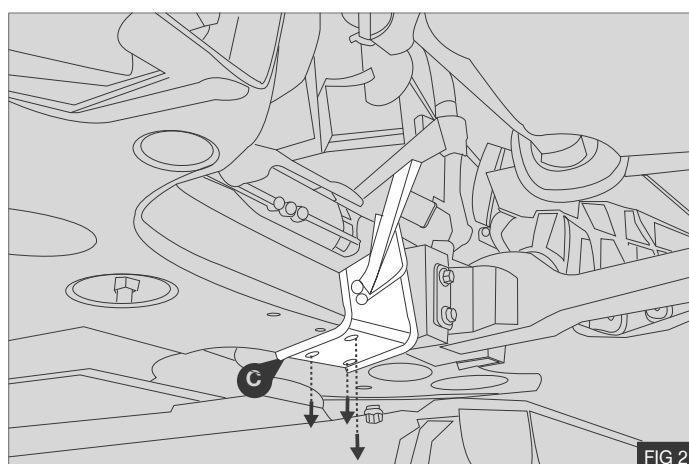
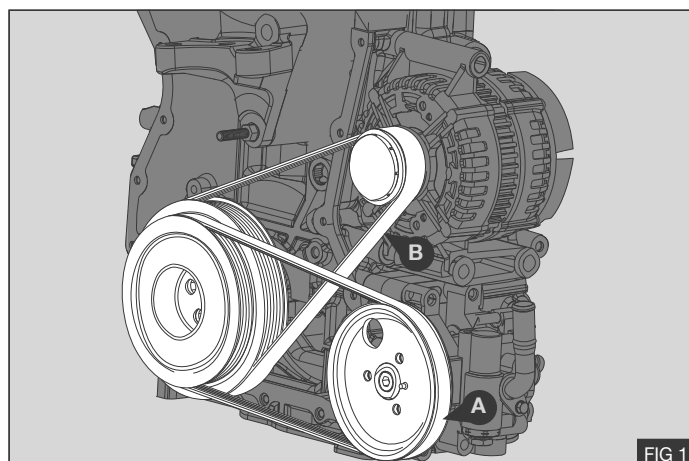

INSTALLATION

1. Fit the supplied back idle pulley (15) onto the original stud (C) located on the engine mount and secure using supplied nut (13) - Fig 2
2. Torque nut (13) to 25 Nm / 18.0 Lb ft using a calibrated torque wrench
3. Fit the supplied idle pulley (16) onto the mounting at point (D) - Fig 3

NB : It may be necessary to remove excess gasket covering the mounting hole (D) - Fig 3

4. Torque the idle pulley bolt to 25 Nm / 18.0 Lb ft using a calibrated torque wrench
5. Remove the original manufacturers wiring loom fitted to the automatic belt tensioner (14) mounting holes - Fig 3
6. Secure the automatic belt tensioner (14) using the two supplied M8 x 45 bolts (11) - Fig 4.

Note: Fit drive belt (17) to the automatic belt tensioner pulley before fitting the tensioner (14)

7. Torque the bolts (11) to 25 Nm / 18 Lb ft using a calibrated torque wrench

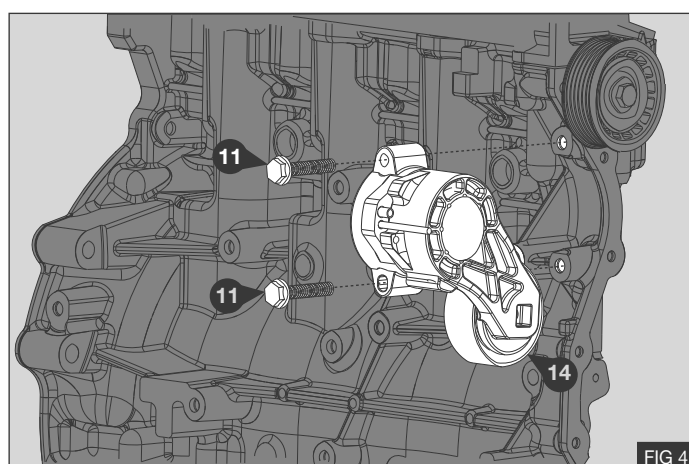
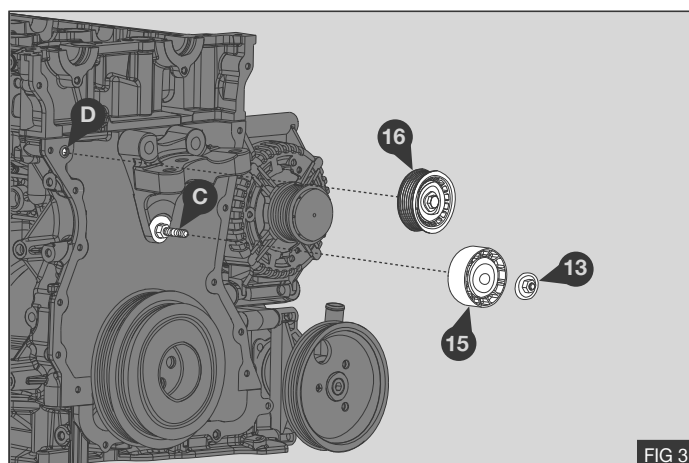

COMPRESSOR BRACKET INSTALLATION

NB: Ensure the correct length bolt is installed in the correct location shown in Fig 5.

1. Install the supplied compressor mount bracket assembly ① in the position shown and secure using bolts M8 x 60 ⑩ , M8 x 45 ⑪ , M8 x 35 ⑫ - Fig 5
2. Torque bolts ⑩ ⑪ ⑫ to 25Nm / 18lb.ft. using a calibrated torque wrench.

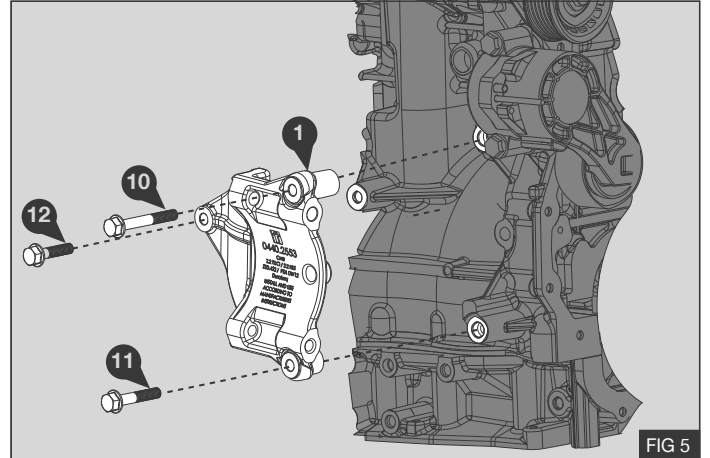

COMPRESSOR MODIFICATION

1. Remove the compressor ear (E) detailed in the drawing - Fig 6.
2. Fit the supplied compressor fittings ⑳ ㉑ and clamp in place with manifold clamp ㉒ and bolt ㉓ - Fig 6

NB: Align supplied suction and discharge fittings as shown in - Fig 6.

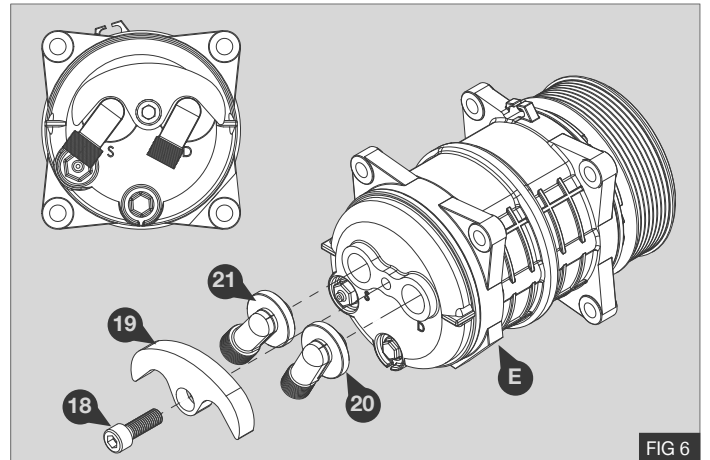

COMPRESSOR INSTALLATION

1. Fit the compressor to the mount bracket assembly ① fixing it with the two supplied bolts M10 x 30 ⑨ and cap screw M10 x 130 ⑦ with Schnorr safety washer ⑥ ,flat washer ⑤ and nut ⑧ - Fig 8

NB: Move and hold the exhaust pipe (D) in the direction shown to allow for the installation of the compressor - Fig 7.

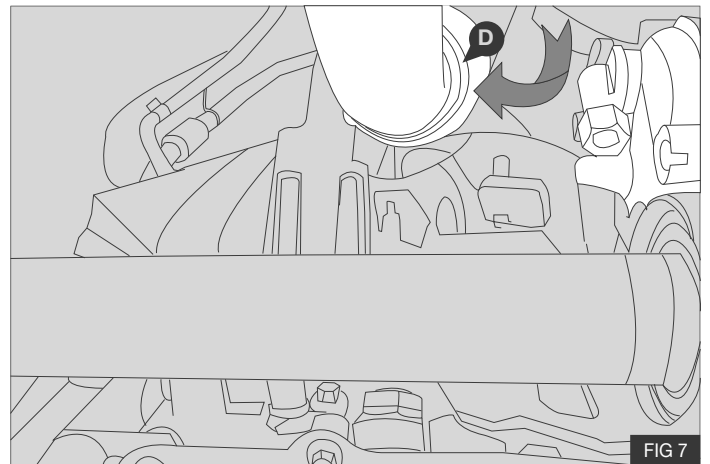

2. Torque the two M10 x 30 bolts ⑨ to 50 Nm / 37 Lb ft using a calibrated torque wrench
3. Torque the M10 x 130 cap screw ⑦ to 50 Nm / 37Lb ft using a calibrated torque wrench
4. Fix the original manufacturers wiring loom previously removed into an appropriate location.

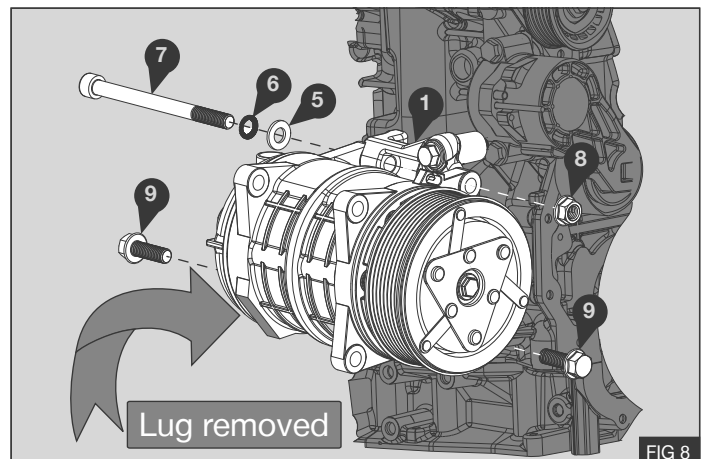

DRIVE BELT

1. Fit the supplied replacement poly groove engine drive belt (17) to the engine in the same configuration in accordance with the original manufacturers design - Fig.9
2. Refit the original power steering stretch self tensioning drive belt (A) using the correct installation tool (Not supplied) - Fig 9

NB: Where applicable and dependent on the compressor model, align the supplied drive belt by installing in the correct clutch groove - Fig.9

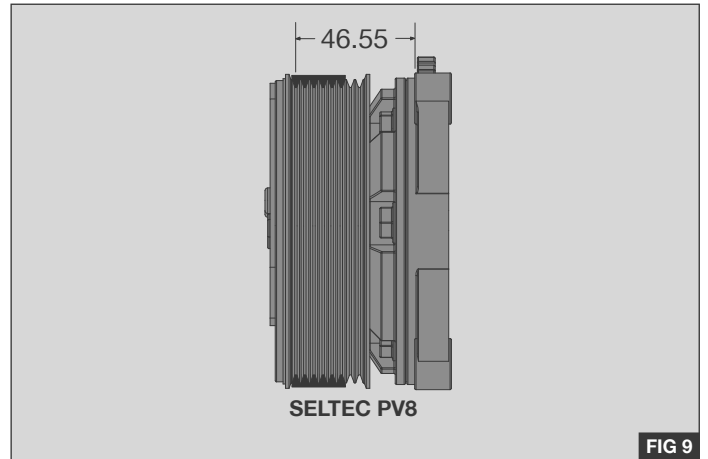

FIG 9

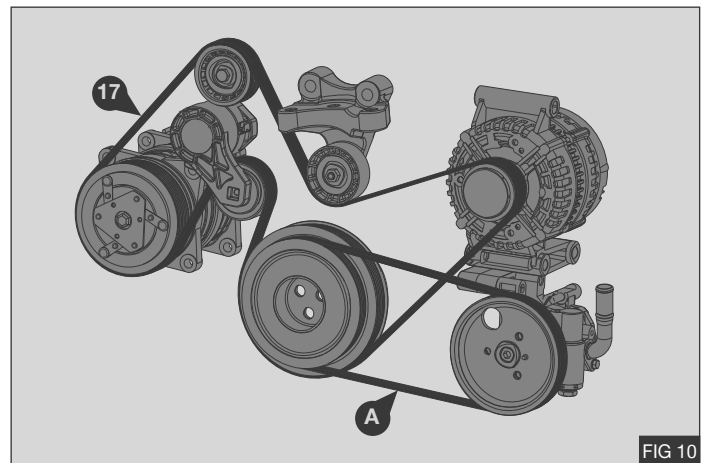

FIG 10

COMPRESSOR HOSES

1. Fit the supplied threaded pillar (26) to the position shown - Fig 10
2. Fit the supplied heat sleeving (22) and (23) to the suction and discharge hoses - Fig 11
3. Secure the suction and discharge hoses using the P-Clip (24) and bolt (25) - Fig 11

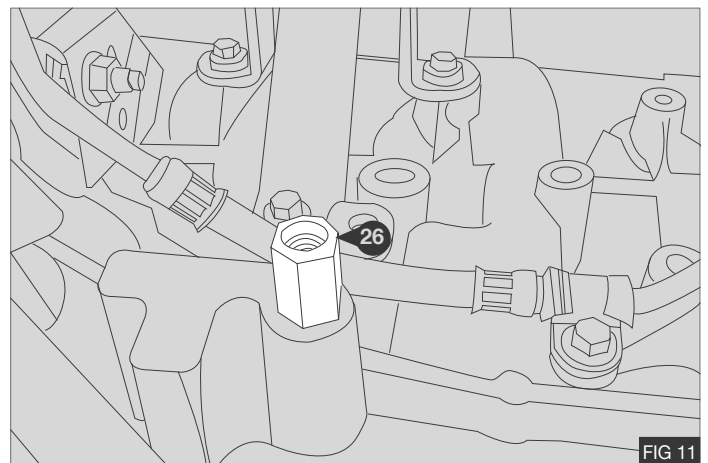

FIG 11

POST INSTALLATION

1. Before starting the engine check all the installed parts and ensure that the belt is installed correctly. Run the unit for at least ten minutes, then check the whole mounting assembly and previously removed parts. Attach the supplied warning label onto a suitable location.

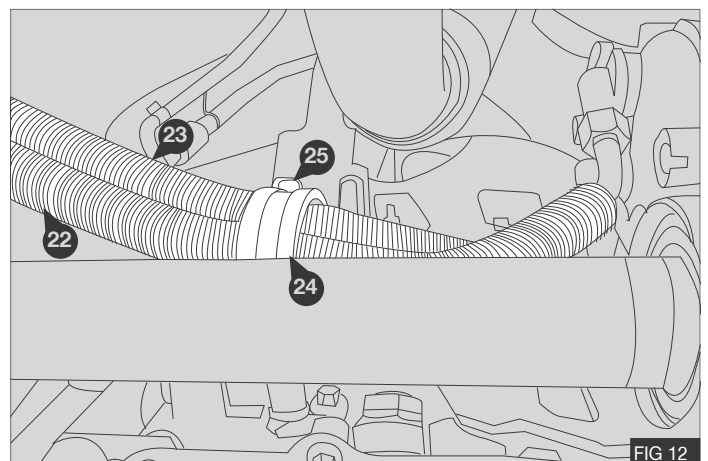

FIG 12

Notes

Notes

Notes